

B.M.B MOTORSPORT ENGINES

FICHES D' IDENTIFICAZIONE HAT 125



CARATTERISTICHE TECNICHE

MOTORE	DUE TEMPI	COSTRUTTORE	BIRELART
RAFFREDDAMENTO	ACQUA	MARCA	B.M.B.
CILINDRATA MAX	125 cc	MODELLO	HAT
CORSA	54 mm	TIPO	T-X
ALESAGGIO MASSIMO	54,30 mm		
POTENZA	32 Hp		
REGIME DI ROTAZIONE	LIMITATO a 16.000 rpm ~		
TIPO AMMISSIONE	LAMELLARE		
CARBURATORE	A FARFALLA Ø 26 mm MAX		
ACCENSIONE	ELETTRONICA		
AVVIAMENTO	ELETTRICO		
FRIZIONE	CENTRIFUGA		



Timbro e firma del costruttore

Foto lato destro



Foto anteriore



Foto lato sinistro



Foto posteriore



SEMICARTER DESTRO

MATERIALE = ALLUMINIO

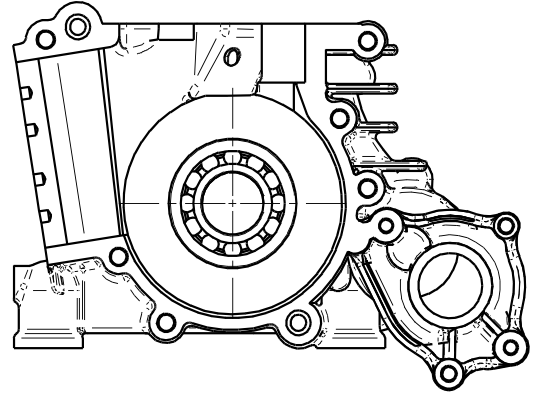
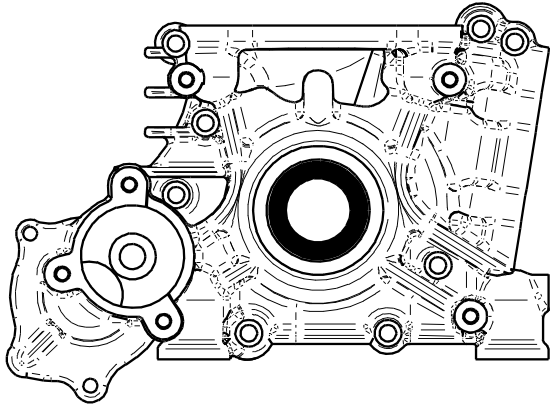

PARAOLIO 40x25x7CON DOPPIO LABBRO IN TEFLON

SEMICARTER SINISTRO

MATERIALE = ALLUMINIO

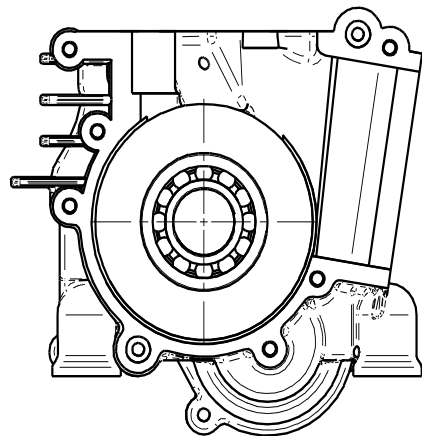
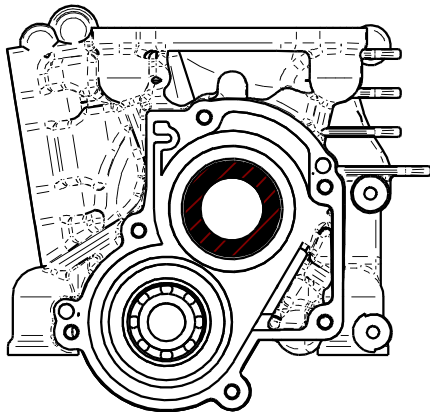

CUSCINETTO 6202 C4 CON GABBIA IN POLIAMIDE
PARAOLIO 40x25x7CON DOPPIO LABBRO IN TEFLON

BASAMENTO

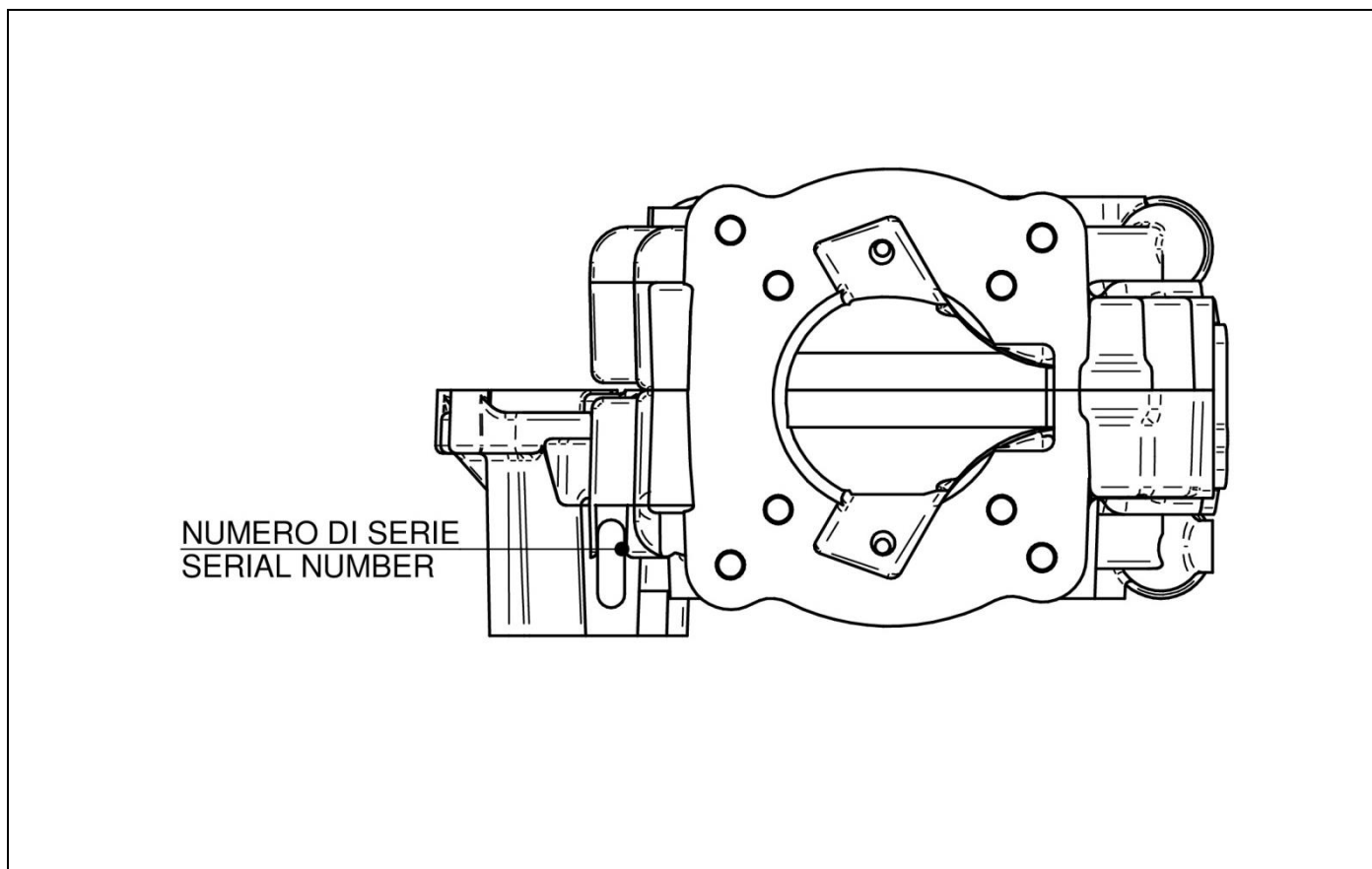

TESTA

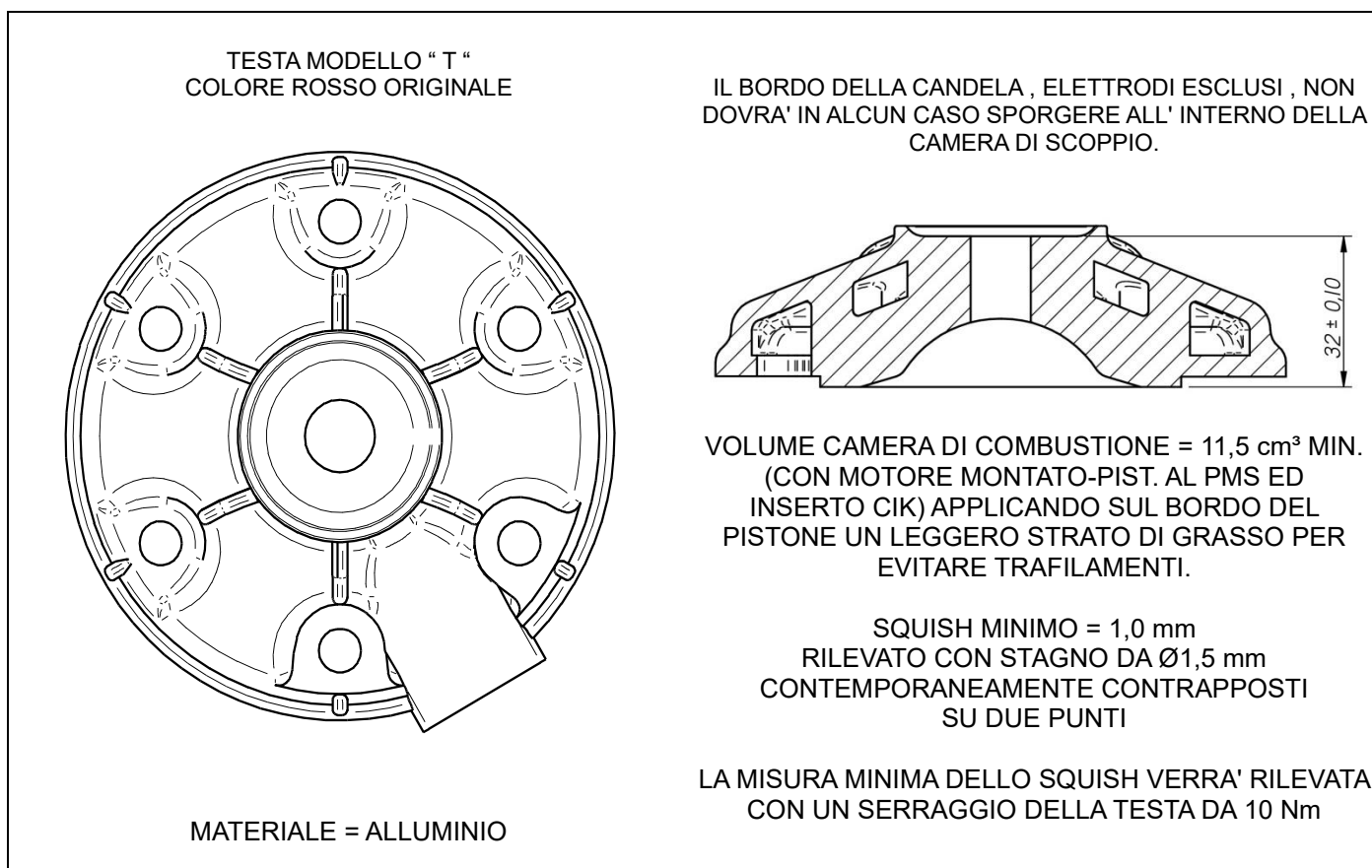

CILINDRO

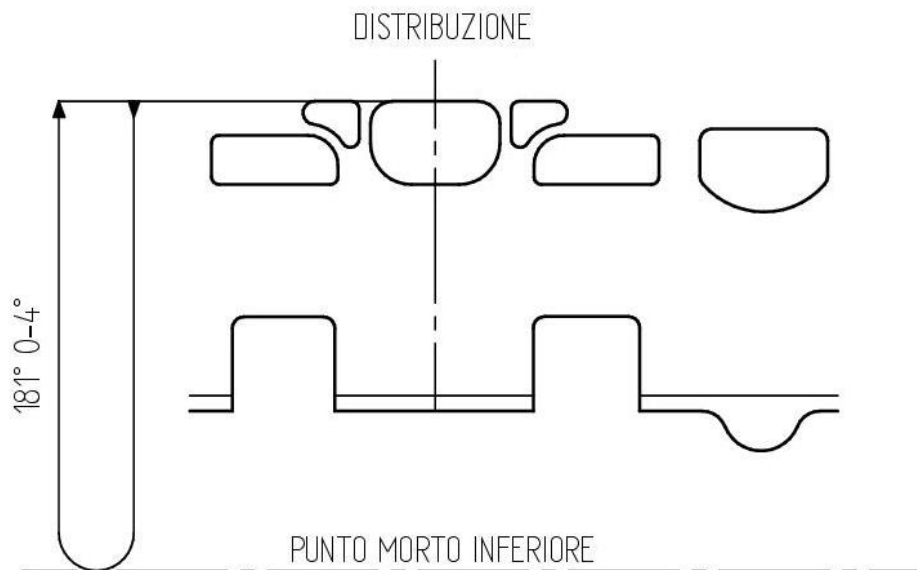
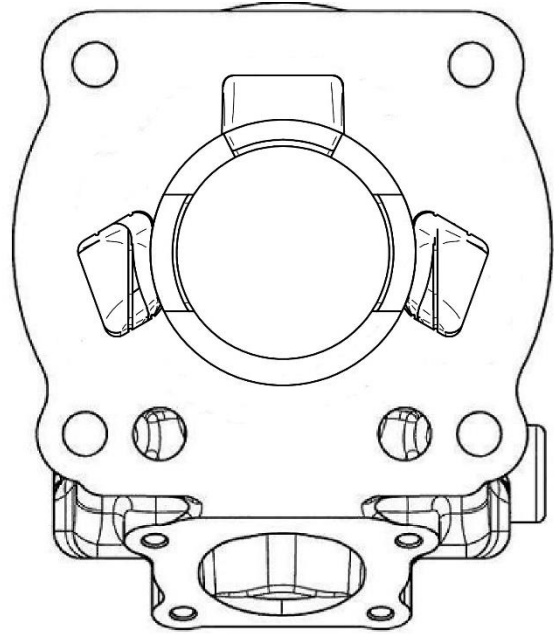
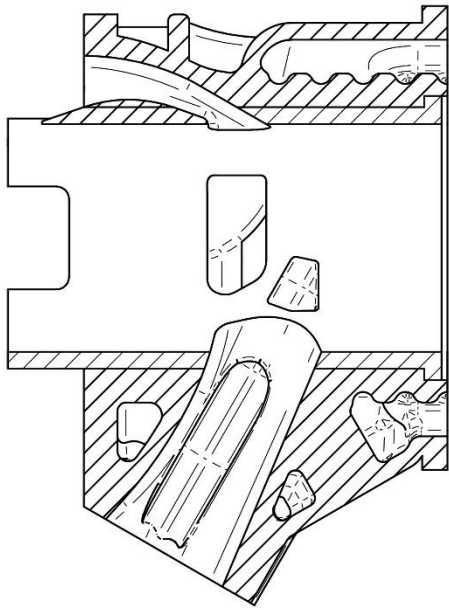

LETTURA ANGOLARE CON SPESSORE 0,20 mm AVENTE LARGHEZZA 5 mm
RIFERIMENTO AL REGOLAMENTO TECNICO ACI SPORT IN VIGORE
MATERIALE DEL CILINDRO = ALLUMINIO MATERIALE DELLA CANNA = GHISA

ALBERO MOTORE

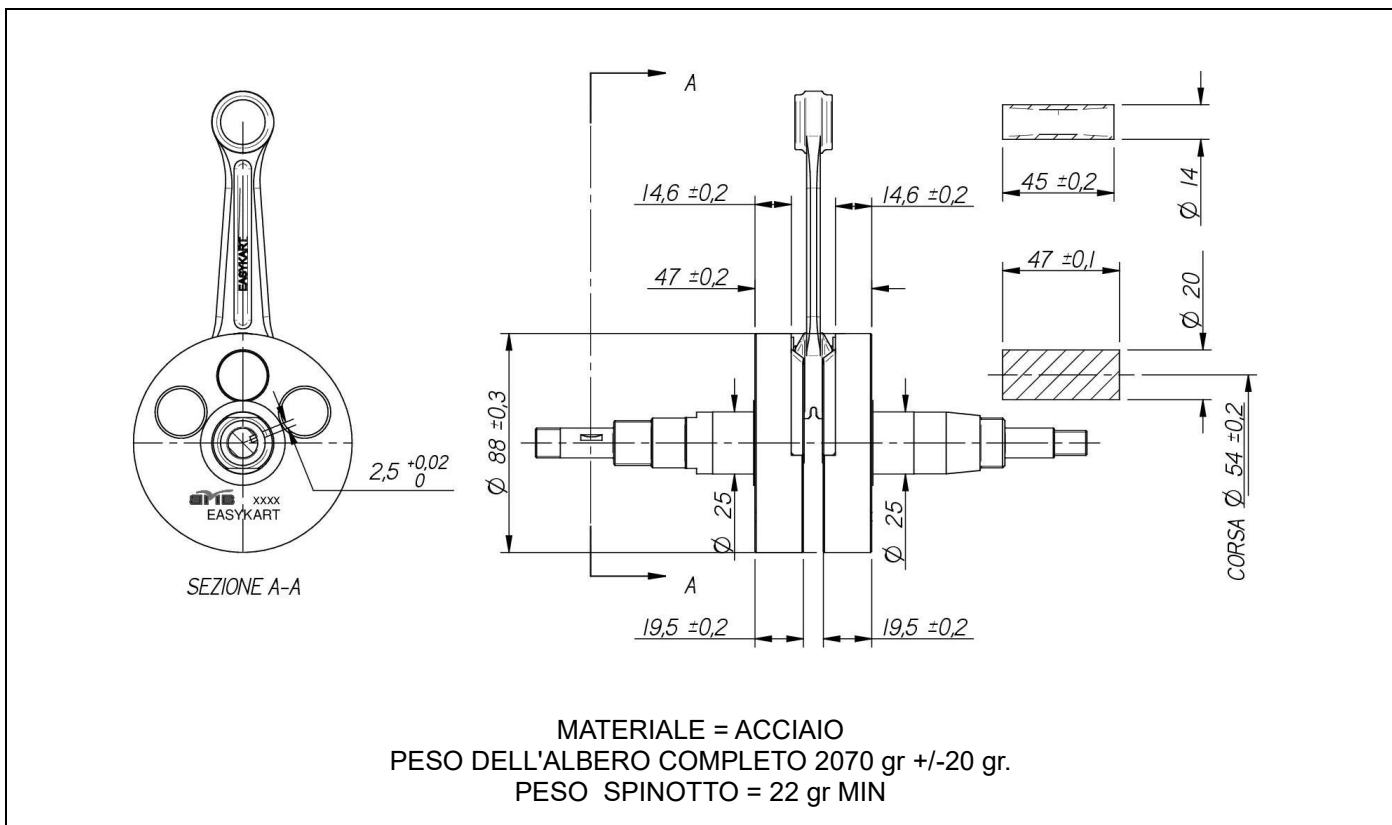

PISTONE

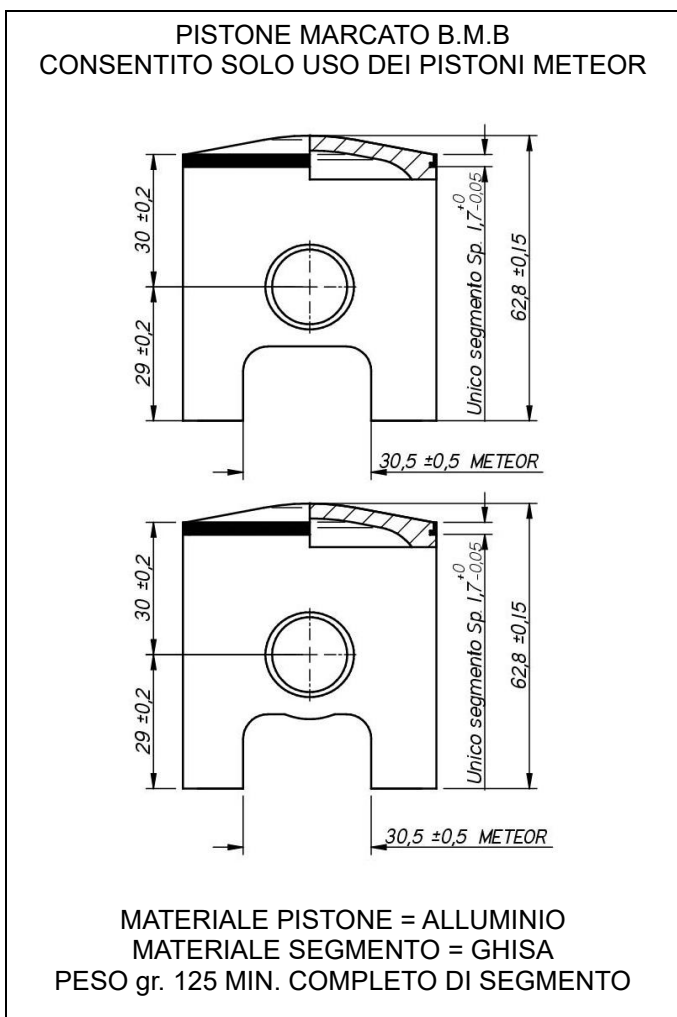

BIELLA

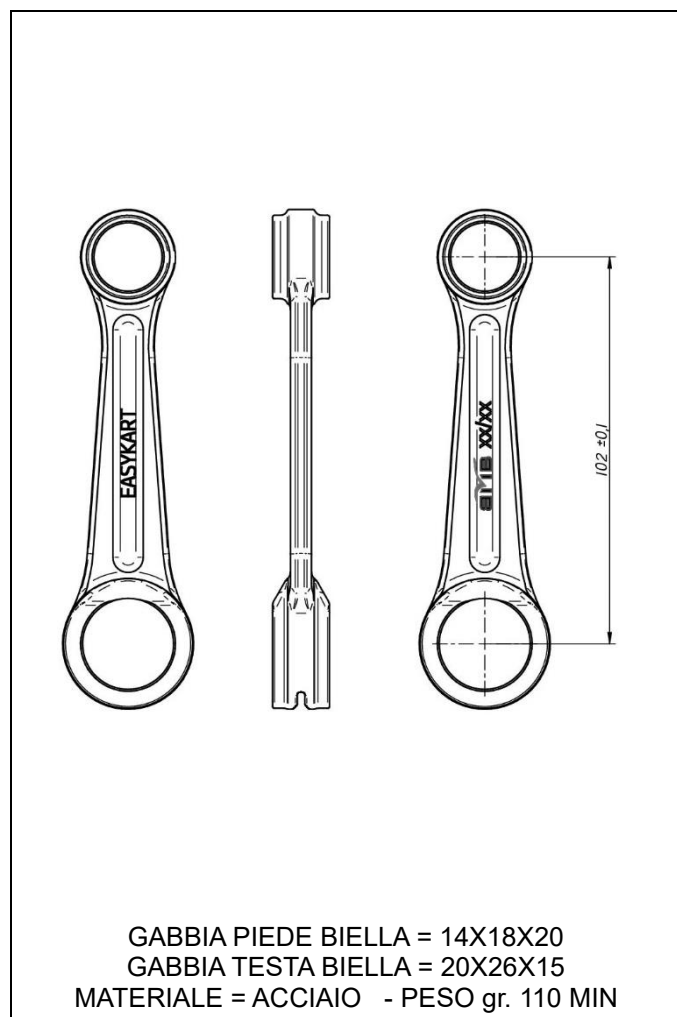

CONTRALBERO

FASE = PUNTO MORTO SUPERIORE

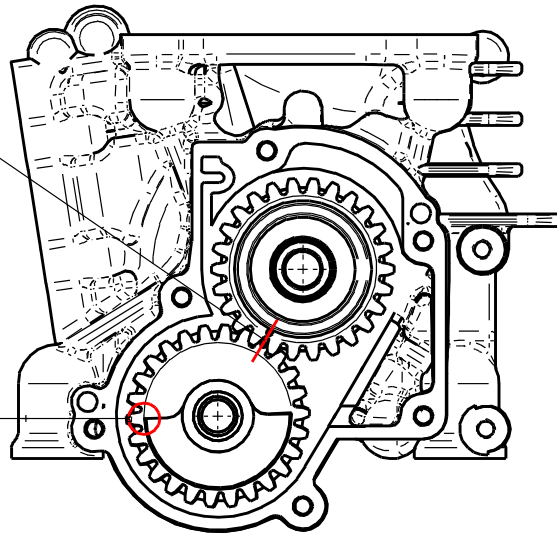
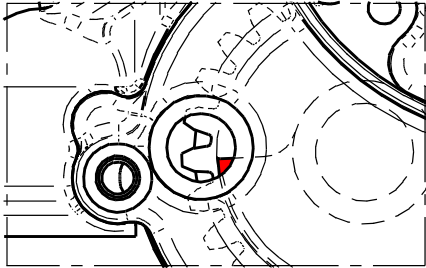
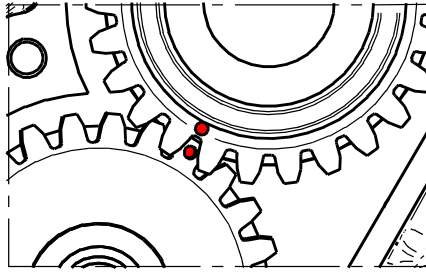

POSIZIONAMENTO CONTRALBERO
AL PMS VISTO DAL LIVELLO OLIO

CONTRALBERO MONOBLOCCO = Z 26 PESO MIN. =250 gr.
INGRANAGGIO PRIMARIO = Z 26 PESO MIN.= 70 gr. +/- 5 gr.

FRIZIONE – CORONA AVVIAMENTO

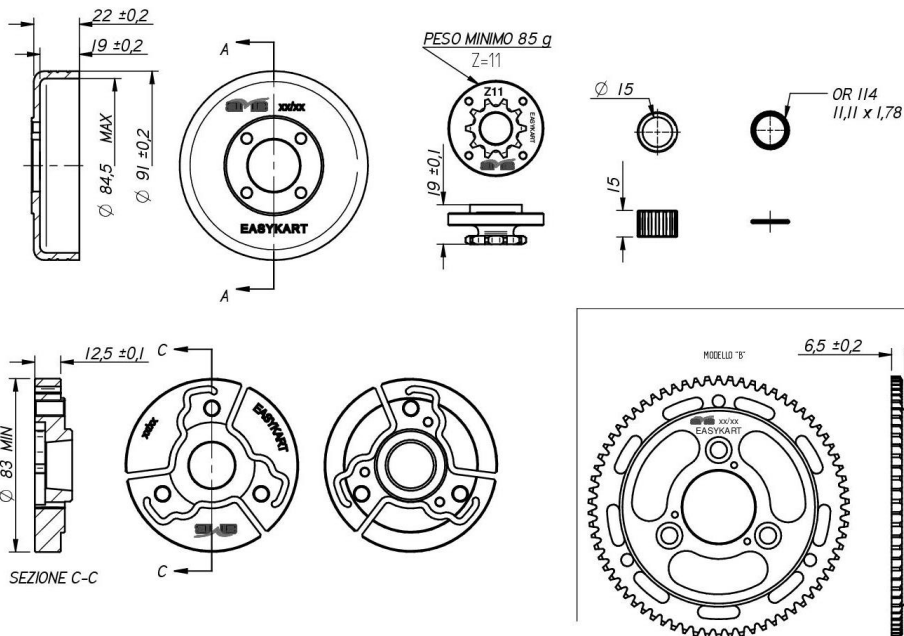

CAMPANA COMPLETA DI PIGNONE MAT. ACCIAIO PESO = 370 g. +/-10g
CORPO FRIZIONE MAT. ACCIAIO PESO = 400 g. MIN.

CORONA AVVIAMENTO Z=70
CORONA MAT. ACCIAIO PESO = 260 g +/- 10g

PACCO LAMELLARE

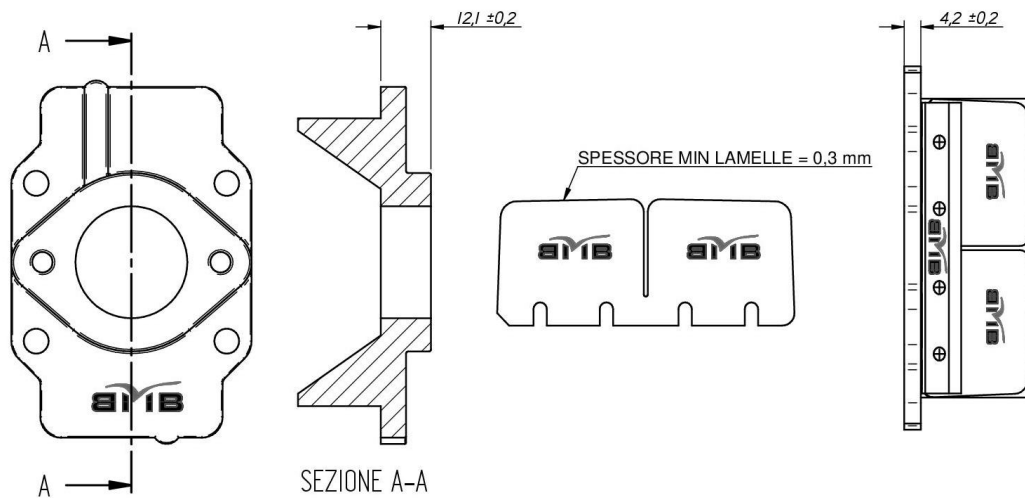

LE LAMELLE NON DEVONO SPORGERE DAL PACCO LAMELLARE

E' VIETATO L'UTILIZZO DI DISTANZIALI TRA IL PIANO DEL CARBURATORE E QUELLO DEL PACCO LAMELLARE , SALVO LA GUARNIZIONE DI SPESSORE MAX. 1,5 mm

CARBURATORE

TRYTON mod. HB-27

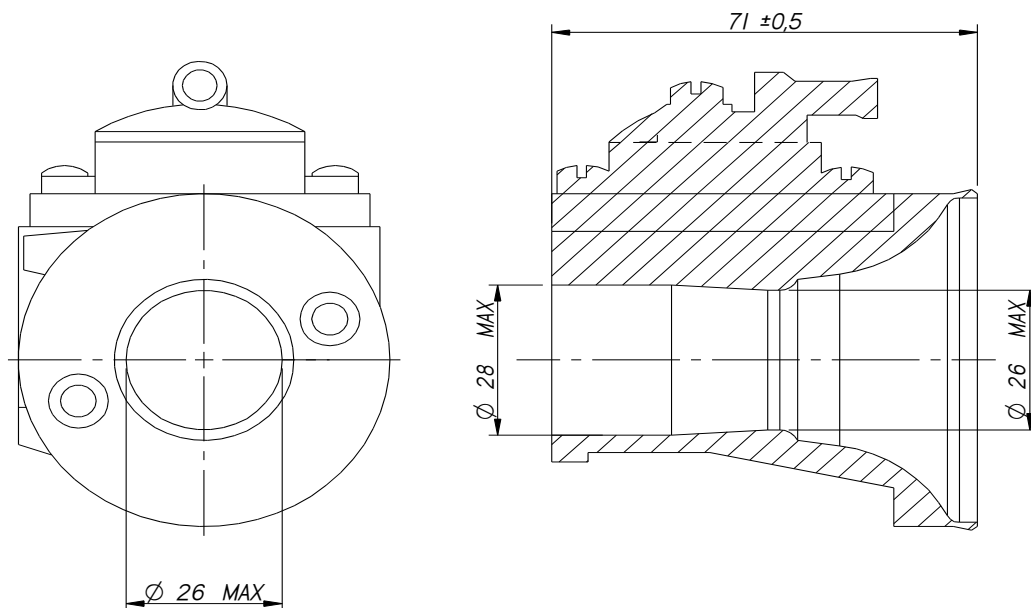

VERIFICATO CON TAMPONE PASSA NON PASSA FORNITO AI COMMISSARI TECNICI DAL PROMOTORE
SONO VIETATE LAVORAZIONI E/O LUCIDATURA DEL CONDOTTO
L'ASPIRAZIONE DELL'ARIA DEVE AVVENIRE ESCLUSIVAMENTE DALLE PRESE D'ARIA DEL FILTRO

SCHEMA IMPIANTO ELETTRICO

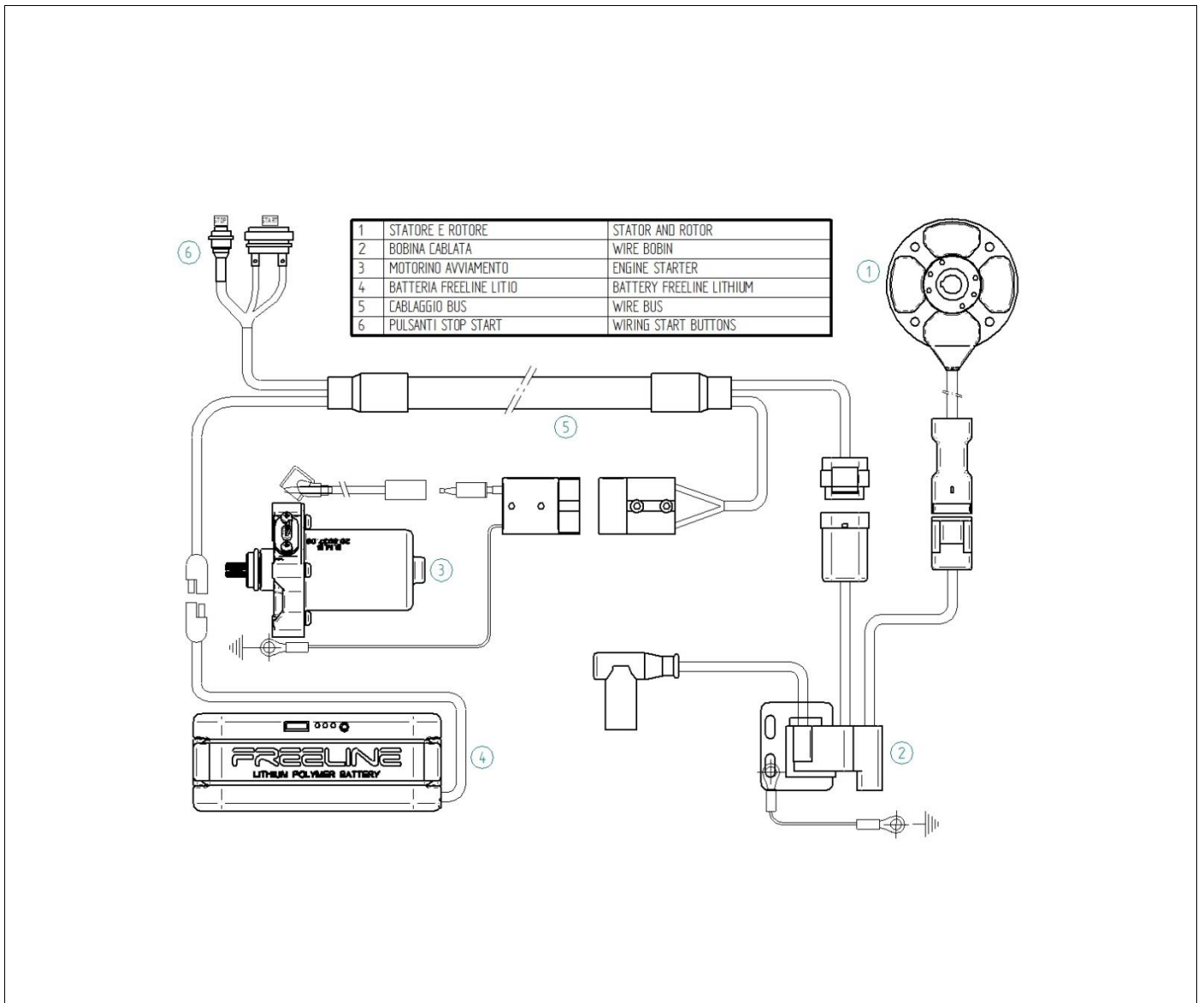

SCHEMA CONTROLLO ANTICIPO



DIAGRAMMA ANTICIPO ACCENSIONE



SILENZIATORE DI SCARICO

MATERIALE : ACCIAIO

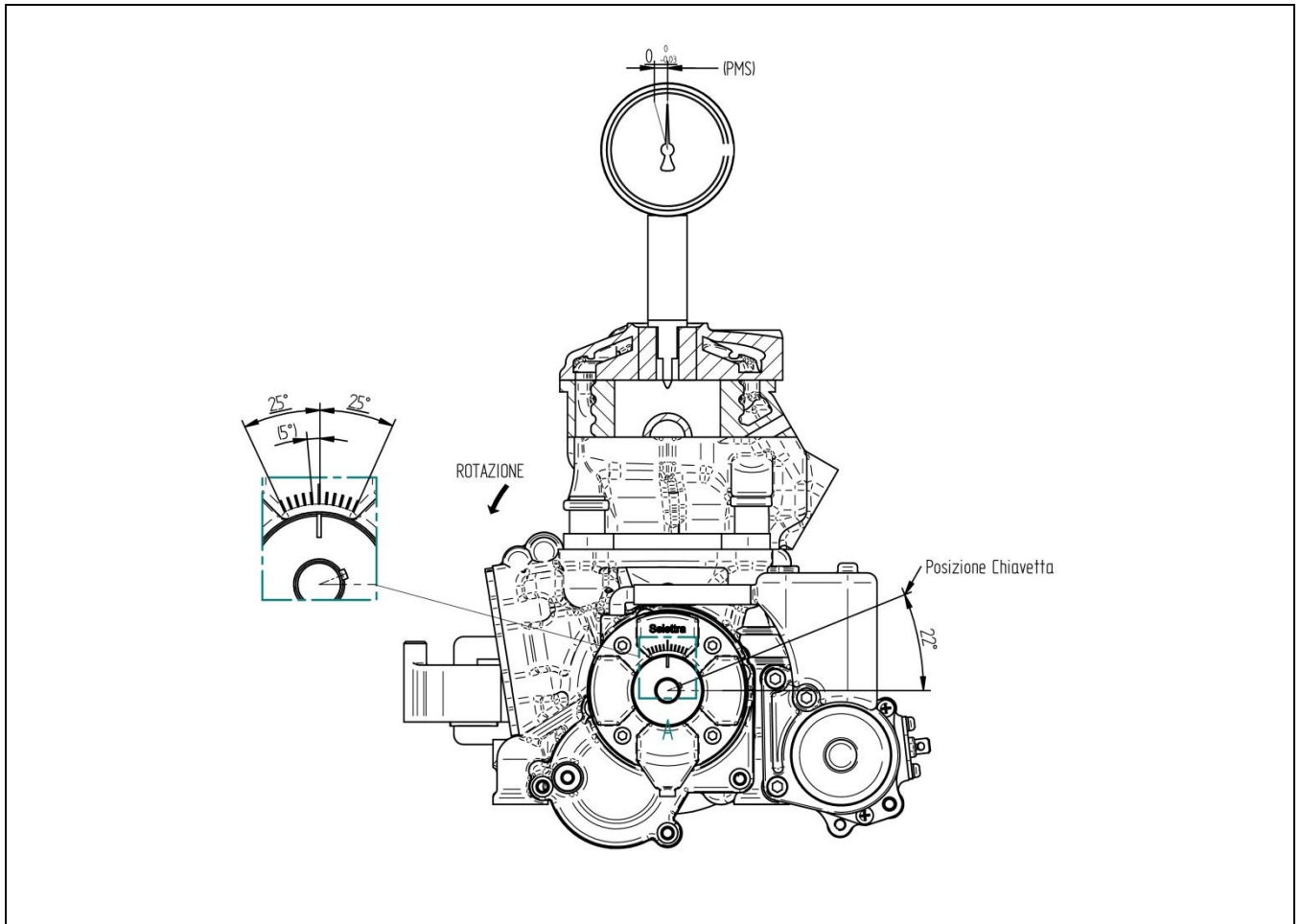
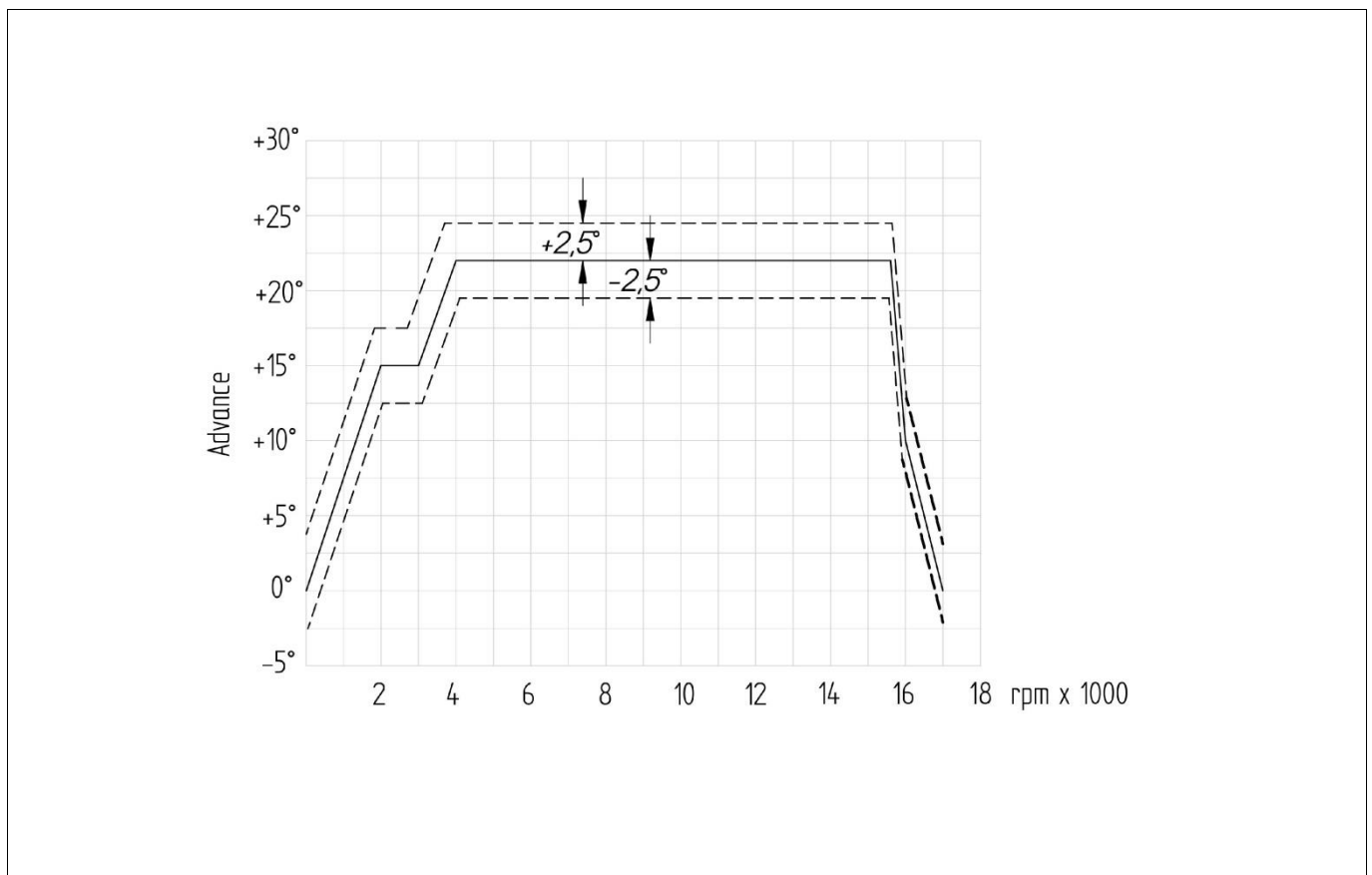
PESO MINIMO 2020 g.

