

PRESS RELEASE N. 5 of 06/11/2024

SUBJECT: **NEW TECHNICAL REGULATIONS EASYKART 2025:**

1. EASYKART 60

• **New carburetor TRYTON MOD. HB-19**

The engine BMB mod. EKL for Easykart 60 must be fitted with TRYTON mod. HB-19 carburetor.



1 – code 40.17330.00-NE - CARBURETOR TRYTON HB-19 – ANODIZED BLACK AS ORIGINAL

2 – code 40.17332.00 - FLANGE GASKET CARBURATORE TRYTON EKL

3 – code 20.10147.06 - TUBE NUTS M6

4 – code 40.17331.00 - ADAPTOR FLANGE CARBURETOR TRYTON HB-19

The Tillotson HL-396A T carburetor as in the technical regulations of 2024 trophy can not be utilized for the 2025 season.

The EKL 60 Academy engine will not have any technical regulation changes and will continue to utilize the Tillotson HL-396A T carburetor.

2. EASYKART 100

• New carburetor TRYTON MOD. HB-24

BMB mod. EKJ for Easykart 100 must be fitted with TRYTON mod. HB-24 carburetor.



1 – code 40.17333.00-BL - CARBURETOR TRYTON HB-24 – ANODIZED BLUE ORIGINAL

2 – code 20.10147.06 - TUBE NUTS M6

3 – code 40.17334.00 - CONVOYER CARBURETOR TRYTON HB-24/27

The carburetor Tillotson HL-397A T and convoyer code 40.9456.00 as in the technical regulations of 2024 trophy can not be utilized for the 2025 season.

3. EASYKART 125 – BMB CHALLENGE

• New convoyer carburetor TRYTON MOD. HB-27

BMB mod. EKA equipped for Easykart 125 and mod. HAT for the category BMB CHALLENGE must be fitted with the new convoyer TRYTON mod. HB-27



1 – code 40.17334.00 - CONVOYER CARBURETOR TRYTON HB-24/27

The previous version of the convoyer code 40.9456.00 as in the technical regulations of 2024 trophy can not be utilized for the 2025 season.

4. EASYKART 60 ACADEMY – EASYKART 100 – EASYKART 125

- Prohibition of use old chassis Easykart mod. L28C-Y – R30C-Y

①

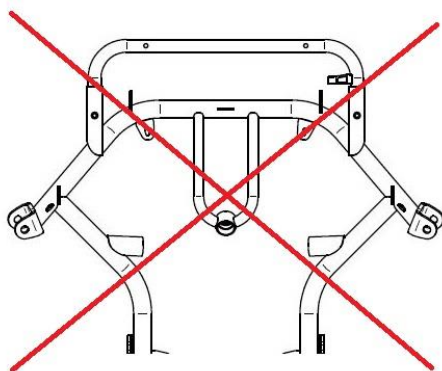

FRAMES NOT COMPLIANT WITH THE 2025 TECHNICAL REGULATION

②

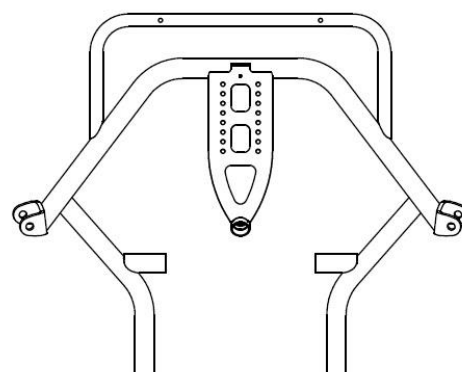

FRAMES COMPLIANT WITH THE 2025 TECHNICAL REGULATION

Chassis mod. R30C-Y e L28C-Y with lower steering shaft support a “U” (1) can no longer be utilized for the ufficiale Easykart trophy 2025 and forward, chassis compliant with 2025 technical regulations are with lower steering shaft support mod. “IRON” (2).

5. NEW PISTON SIZES FOR BMB ENGINES

We have introduced to our range in the BMB price list the following pistons:

code 10.16980.00 - PISTON EKL 42.45 – ENGINE BMB EKL 60cc

code 10.16981.00 - PISTON EKJ 50.84 – ENGINE BMB EKJ 100cc

code 10.16982.00 - PISTON EKA/HAT 54.01 – ENGINE BMB EKA/HAT



For further information and to purchase new parts, please contact the authorized Easykart dealers directly. Find the complete list of dealers at the following link:

<https://www.easykart.it/single-page.asp?id=1>

BIREL ART S.R.L.
Easykart Division